

Thermo Top Evo

Quick and reliable starting in winter

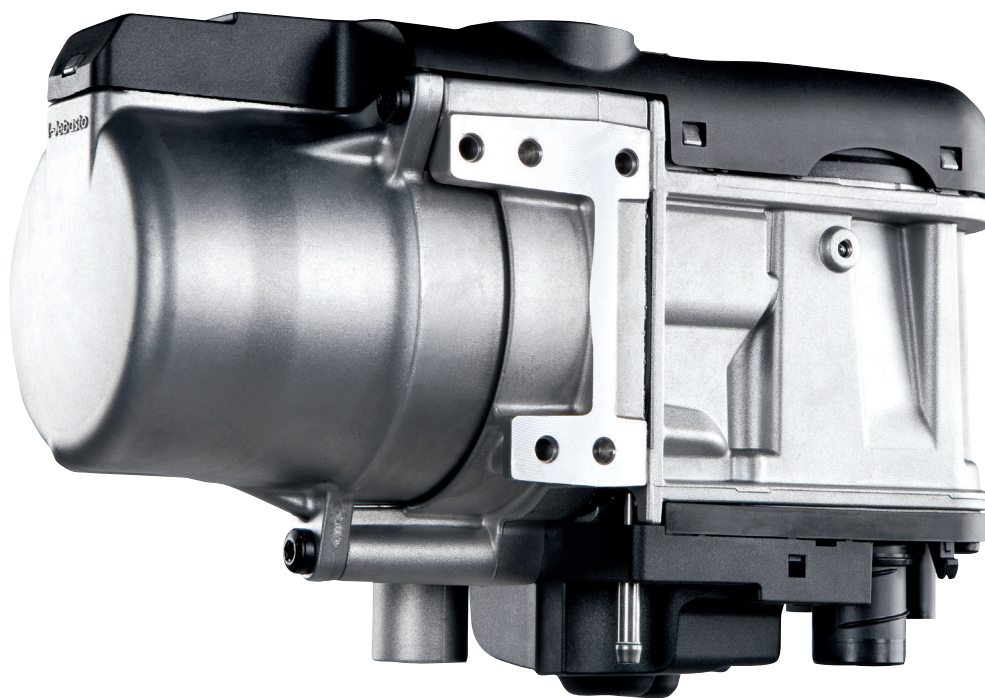

The Thermo Top Evo parking heater generation has been developed especially for new vehicles and those with restricted installation space. Thanks to the efficient heating system, the vehicle is ready to start quickly and reliably. Icy windows can be defrosted within a very short time and the cabin heats up very quickly.

There is a choice of three heating capacities, depending on the size of the vehicle. Thanks to its innovative control system, the Thermo Top Evo 5+ can be used to heat up very large interiors.

Key benefits at a glance:

- Automatic heating capacity regulation for low fuel consumption and minimal emissions in operation
- Diesel versions with continuous heating function
- 5+ version for particularly fast defrosting of the windshield
- Universal as well as vehicle-specific installation kits available
- Flexibel control elements and accessories to facilitate installation



Car



Light Vehicle



Recreational Vehicle



Off-Highway



Special Vehicle

Technical specifications

	Thermo Top Evo 4		Thermo Top Evo 5 / 5+*		Thermo Top Evo 5 Heavy Duty / RV Classic	
Model Overview	Diesel	Gasoline	Diesel	Gasoline	Heavy Duty Diesel	RV Classic Diesel
ECE approval number ECE R122 (heating)	E1 00 0258		E1 00 0258		E1 00 0258	
ECE approval number ECE R10 (EMC)	E1 06 5627		E1 06 5627		E1 06 5627	
Declaration of Conformity (CE)	CE		CE		CE	
Heating capacity (part load/full load) [kW]	2,5 / 4,0	2,8 / 4,0	2,5 / 5,0	2,8 / 5,0	2,5 / 5,0	1,8 / 5,0
Fuel consumption (part load/full load) [l/h]	0,31 / 0,49	0,39 / 0,56	0,31 / 0,62	0,39 / 0,70	0,31 / 0,62	0,23/ 0,62
Nominal voltage (V)	12		12		12	
Communication	analog / W-Bus		analog / W-Bus		analog / W-Bus	
Function	according Control up to 120min		according Control up to 120min		continuous heating	
Rated Power Consumption, part load/full load (W)	12/21	15/21	12/33	15/33	12/33	12/33
Fuels	Diesel (DIN EN 590)	E0-E10 (EN228)	Diesel (DIN EN 590)	E0-E10 (EN228)	Diesel (DIN EN 590)	
Operating Temperature (°C)	-40 to 60		-40 to 60		-40 to 60	
Dimensions L x W x H (mm)	218 x 91 x 147		218 x 91 x 147		218 x 91 x 147	
Weight (kg)	2.1		2.1		2.1	
Coolant Pump CP4847						
Volume flow against 140mbar / 23° C (l/h)	500		500		500	
Dimensions L x W x H (mm)	96 x 75 x 80		96 x 75 x 80		96 x 75 x 80	
Weight (kg)	0.3		0.3		0.3	

* The Thermo Top Evo 5+ unit has an innovative system for controlling the coolant circuit.

Scope of delivery

- Heater, coolant pump U4847 Econ, fuel pump DP42, heater cable harness

Installation kit

- Universal installation material for water application, air flow material for burning and exhaust, fuel line and fuel extraction

Control elements



▪ ThermoConnect TCon2



▪ Remote control Telestart T99



▪ Remote control Telestart T100 HTM



▪ MultiControl (RV Classic) (12V)